

单作用油缸

1. 烤漆表面耐腐蚀且美观
2. 液压缸内壁镀铬处理 耐腐蚀，增加产品使用寿命
3. 外螺纹、柱塞螺纹及底座安装孔提供可靠便捷的安装
4. 内置高强度弹簧保证活塞杆快速完全复位
5. 高质量3/8-18NPT快速接头

Series Single Acting Cylinder

1. Baked enamel finish for increased corrosion resistance
2. Chrome plated Plunger resists wear and rust and extending life
3. Collar Thread permits easy fixturing
4. Heavy Duty Return Spring
5. 3/8 NPT female coupler included

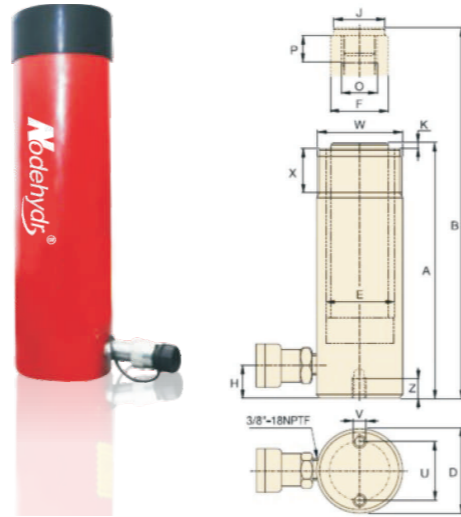

参数/Specifications

Model 型号	Capacity 承载能力 Ton(KN)	Stroke 行程 mm	Active Area 有效面积 cm ²	Oil Capacity 液压油容量 cm ³	Collapsed Height 本体高度 A mm	Extended Height 最大高度 B mm	Outer ring of thread 螺纹外径 C un	Outside Diameter 外径 D mm	Piston rod Diameter 活塞杆直径 F mm	Installation dimensions 底座安装尺寸		Weight 重量 kg	
										Thread Diameter u mm	Thread V un		
NC-50	5(45)	16	7	11	41	57	-	59x42	25	28	5.6mm	1	
NC-51		25	7	17	110	135	1 1/2"-16	38	25	25	1/4"-20	1	
NC-53		76	7	53	165	241	1 1/2"-16	38	25	25	1/4"-20	1.5	
NC-55		127	7	87	216	343	1 1/2"-16	38	25	25	1/4"-20	1.9	
NC-57		178	7	123	273	451	1 1/2"-16	38	25	25	1/4"-20	2.4	
NC-59	232	7	160	324	556	1 1/2"-16	38	25	25	1/4"-20	2.8		
NC-101	10(101)	25	14.5	38	90	115	2 1/4"-14	57	38	39	5/16"-18	1.8	
NC-102		54	14.5	78	121	175	2 1/4"-14	57	38	39	5/16"-18	2.3	
NC-104		105	14.5	151	171	276	2 1/4"-14	57	38	39	5/16"-18	3.3	
NC-106		156	14.5	225	248	404	2 1/4"-14	57	38	39	5/16"-18	4.4	
NC-108		203	14.5	294	298	501	2 1/4"-14	57	38	39	5/16"-18	5.4	
NC-1010		257	14.5	370	349	606	2 1/4"-14	57	38	39	5/16"-18	6.4	
NC-1012		305	14.5	440	400	705	2 1/4"-14	57	38	39	5/16"-18	6.8	
NC-1014		356	14.5	515	451	807	2 1/4"-14	57	38	39	5/16"-18	8.2	
NC-151		15(142)	25	21	52.5	124	149	2 3/4"-16	69	42	47	3/8"-16	3.03
NC-152			51	21	107.5	149	200	2 3/4"-16	69	42	47	3/8"-16	4.1
NC-154	102		21	214	200	302	2 3/4"-16	69	42	47	3/8"-16	5	
NC-156	152		21	319	272	424	2 3/4"-16	69	42	47	3/8"-16	6.8	
NC-158	203		21	420	322	525	2 3/4"-16	69	42	47	3/8"-16	8.2	
NC-1510	254		21	533	373	627	2 3/4"-16	69	42	47	3/8"-16	9.5	
NC-1512	305		21	640	424	729	2 3/4"-16	69	42	47	3/8"-16	10.9	
NC-1514	356		21	747	475	831	2 3/4"-16	69	42	47	3/8"-16	11.8	
NC-251	25(245)		25	33.2	85	140	165	3 5/16"-12	86	57	58	1/2"-13	5.9
NC-252			51	33.2	169	165	216	3 5/16"-12	86	57	58	1/2"-13	6.4
NC-254		102	33.2	339	216	318	3 5/16"-12	86	57	58	1/2"-13	8.2	
NC-256		159	33.2	528	273	432	3 5/16"-12	86	57	58	1/2"-13	10	
NC-258		210	33.2	697	324	534	3 5/16"-12	86	57	58	1/2"-13	12.3	
NC-2510		260	33.2	863	375	635	3 5/16"-12	86	57	58	1/2"-13	14.1	
NC-2512		311	33.2	1033	425	736	3 5/16"-12	86	57	58	1/2"-13	16.3	
NC-2514		362	33.2	1202	476	838	3 5/16"-12	86	57	58	1/2"-13	17.7	
NC-308		30(295)	210	42	919	387	597	3 5/16"-12	102	57	-	-	18.1
NC-502			51	70.8	362	176	227	5"-12	127	80	95	1/2"-13	15
NC-504	50(498)	102	70.8	722	227	329	5"-12	127	80	95	1/2"-13	19.1	
NC-506		159	70.8	1127	283	442	5"-12	127	80	95	1/2"-13	23.2	
NC-5013		337	70.8	2388	461	798	5"-12	127	80	95	1/2"-13	37.7	
NC-756	75(719)	156	103.8	1619	286	422	5 3/4"-12	146	95	-	-	29.5	
NC-7513		334	103.8	3467	492	826	5 3/4"-12	146	95	-	-	59	
NC-1006	100(934)	168	132.6	2225	357	525	5 3/4"-12	178	105	139	3/4"-10	59	
NC-10010		260	132.6	3445	449	709	5 3/4"-12	178	105	139	3/4"-10	72.6	

双作用液压缸

1. 外环螺纹，柱塞螺纹何底部安装孔便于固定
2. 可拆卸鞍座，工作中可保护柱塞杆
3. 烤漆表面耐腐蚀且美观
4. 内置安全阀起防过载保护
5. 高质量的3/8" NPT母接头



ND-Series Double Acting CylinderKB

1. Collar Threads, Plunger threads and base mounting holes for easy fixturing
2. Removable hardened saddles protect during lifting and pressing
3. Baked enamel finish for increased corrosion resistance
4. Built in safety valve prevents accidental over-loaded
5. 3/8" NPT female coupler included

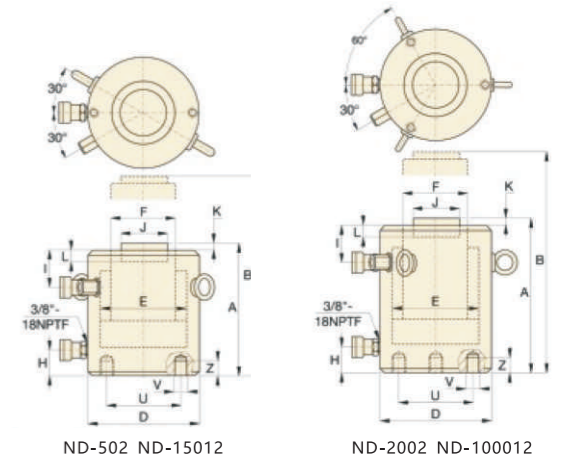

参数/Specifications

Model 型号	Capacity 承载能力 70Mpa Ton(KN)	Stroke 行程 mm	Capacity 承载能力		Active Area 有效面积		Oil Capacity 液压油容量		Collapsed Height 本体高度 A mm	Extended Height 最大高度 B mm	Thread specification 螺纹规格 C mm	Thread length 螺纹长度 X mm	Outside Diameter 外径 D mm	Piston rod Diameter 活塞杆直径 F mm	Installation dimensions 底座安装尺寸			Weight 重量 kg
			Lifting 举起	Return 返回	Lifting 举起	Return 返回	Lifting 举起	Return 返回							Bolt Diameter 螺栓直径 U mm	Thread 螺纹 V mm	Depth 深度 Z mm	
			mm	Ton	Ton	cm ²	cm ²	cm ³							cm ³	mm	mm	
ND-1010	10(101)	254	10.1	3.4	14.5	4.9	368.3	124.46	409	663	2 1/4"-14UNC	26	73	35	-	-	-	12
ND-1012		305	10.1	3.4	14.5	4.9	442.25	149.45	457	762	2 1/4"-14UNC	26	73	35	-	-	-	14
ND-308	30(295)	209	29.3	12.7	41.9	18.1	875.71	378.29	387	596	3 5/16"-12UNC	49	105	55	-	-	-	20
ND-3014		368	29.3	12.7	41.9	18.1	1541.92	666.08	549	917	3 5/16"-12UNC	49	105	55	-	-	-	31
ND-506	50(498)	156	49.6	14.4	70.9	20.6	1106.04	321.36	331	487	5"-12UNC	44	127	80	-	-	-	30
ND-5013		334	49.6	14.4	70.9	20.6	2368.06	688.04	509	843	5"-12UNC	44	127	80	-	-	-	52
ND-5020	75(718)	511	49.6	14.4	70.9	20.6	3622.99	1052.66	733	1244	5"-12UNC	44	131.5	80	76	1/2"-13UNC	25	70
ND-756		156	72.7	23.1	103.9	33	1620.84	514.8	347	503	5 3/4"-12UNC	38	146	95	-	-	-	41
ND-7513	95(933)	333	72.7	23.1	103.9	33	3459.87	1098.9	525	858	5 3/4"-12UNC	38	146	95	-	-	-	68
ND-1006		168	92.9	43.3	133	61.9	2234.4	1039.92	357	525	6 7/8"-12UNC	50	177	95	139	3/4"-10UNC	25	61
ND-10013	140(1386)	333	92.9	43.3	133	61.9	4428.9	2061.27	524	857	6 7/8"-12UNC	50	177	95	139	3/4"-10UNC	25	93
ND-10018		460	92.9	43.3	133	61.9	6118	2847.4	687	1147	6 7/8"-12UNC	50	177	95	139	3/4"-10UNC	25	117
ND-1502	200(1995)	57	140.7	68	201	97.2	1145.7	554.04	196	253	8"-12UNC	-	204	115	-	-	-	49
ND-1506		156	140.7	68	201	97.2	3135.6	1516.32	385	541	8"-12UNC	55	204	115	158	3/4"-16UNF	28	93
ND-15013		333	140.7	68	201	97.2	6693.3	3236.76	582	915	8"-12UNC	55	204	115	158	3/4"-16UNF	28	124
ND-2006	300(3201)	152	98.2	283.5	283.5	140.4	4309.2	2134.08	430	582	9 3/4"UN	-	248.5	135	127	1"-8UNC	25	147
ND-20013		330	98.2	283.5	283.5	140.4	9355.5	4633.2	608	938	9 3/4"UN	54	248.5	135	127	1"-8UNC	25	199
ND-3006	153	316.5	167	452.4	238.6	6921.72	3650.58	485	638	12 1/4"UN	58	312	165	158	1 1/4"-7UNC	44	200	